

Quietflow 'SQT' Electrical Information

Fixed Speed Connection c/w Auto-Changeover Panel

(Auto-Changeover Panel Type 149-IACO1/EL/DS/VFC)

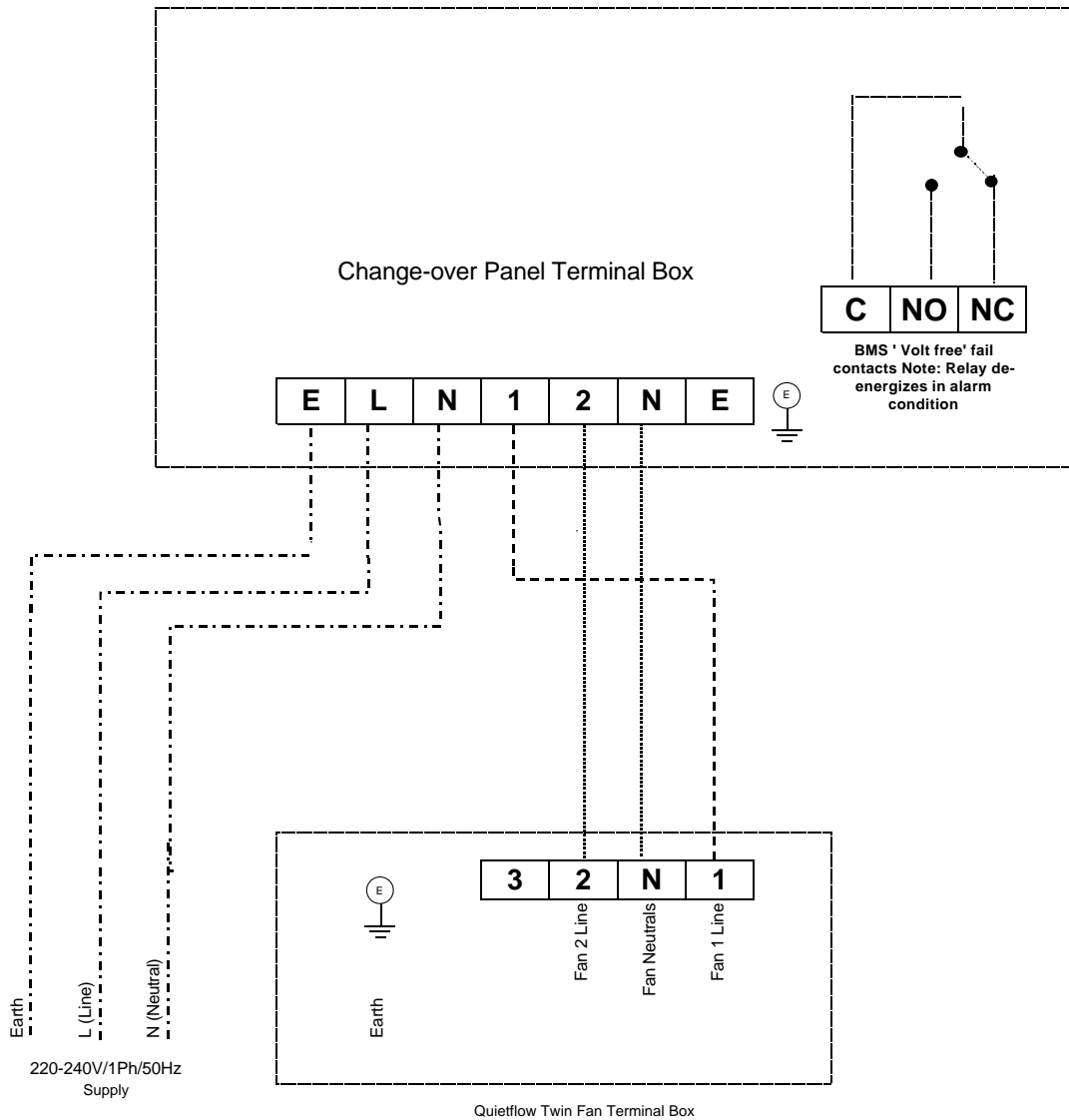

NOTE: THE ABOVE WIRING DIAGRAM APPLIES TO **ELTA FANS** CHANGE-OVER PANELS ONLY. FOR USE WITH ALTERNATIVE CHANGE-OVER PANELS REFER TO MANUFACTURER'S WIRING DIAGRAM.