

## Compact 'SCP/D' 3Ph Electrical Information

### Fixed Speed Connection

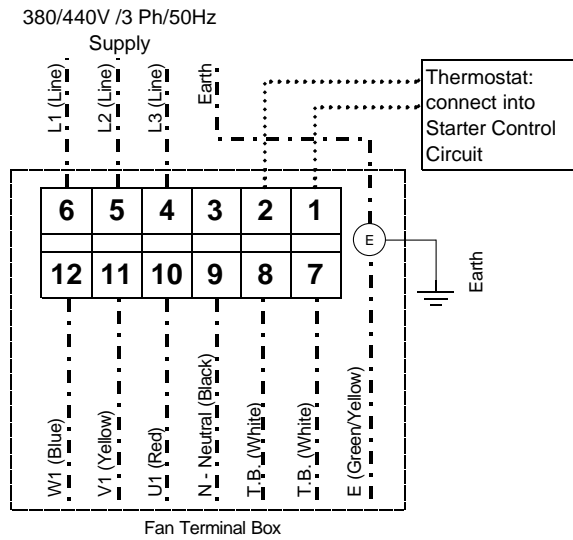

### Variable Speed Connection

(Unit c/w 3Ph Transformer Controller Type 149-TC3\*\*)

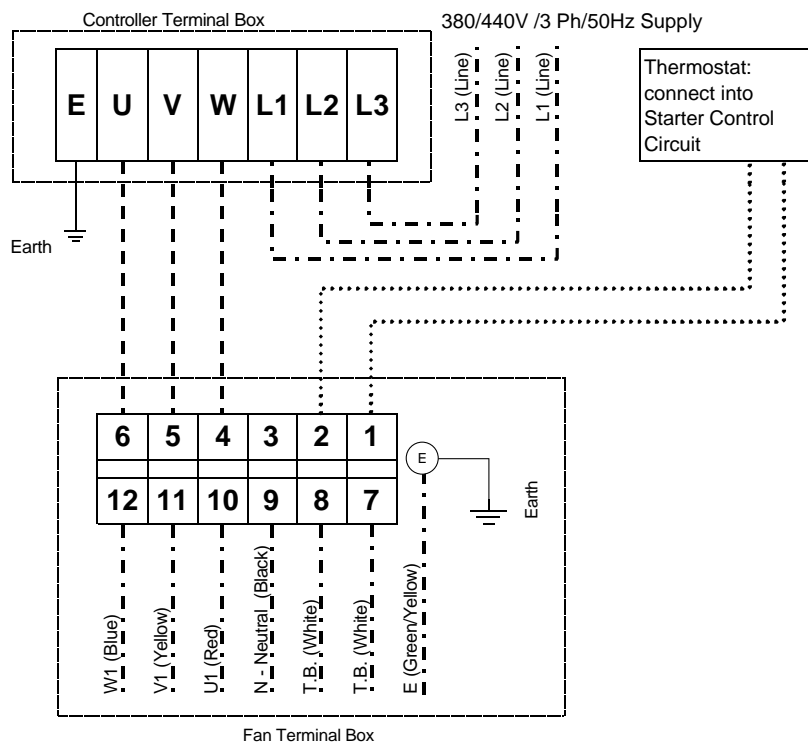

**NOTE:** THE ABOVE WIRING DIAGRAM APPLIES TO INSTALLATIONS WHERE **ELTA FANS** CONTROLLERS ARE USED. FOR ALTERNATIVE CONTROLLERS REFER TO MANUFACTURER'S WIRING DIAGRAM. FAILURE TO CONNECT BUILT-IN MOTOR THERMOSTAT PROTECTION MAY INVALIDATE WARRANTY. TO CHANGE ROTATION INTERCHANGE ANY TWO SUPPLY LEADS.