

Compact 'SCP/D' 1ph Electrical Information Fixed Speed Connection

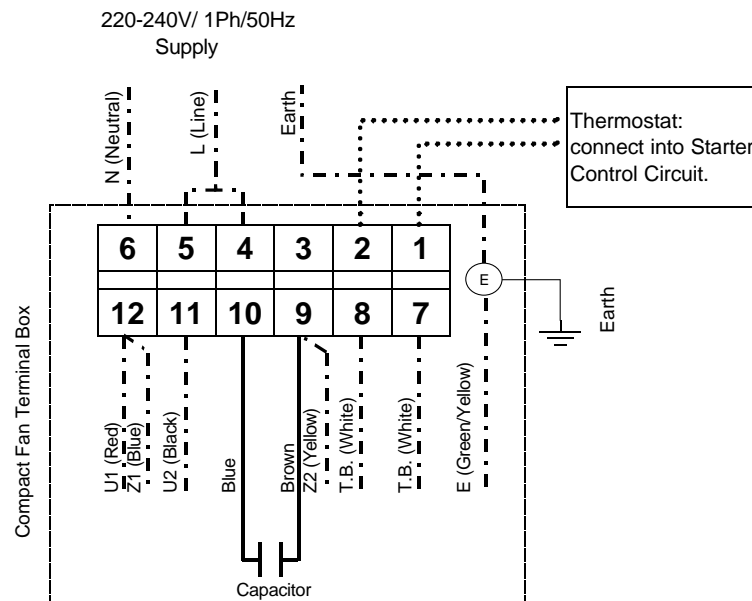

Variable Speed Connection

(Unit c/w Speed Controller Types 149-EL31 & 149-EL61)

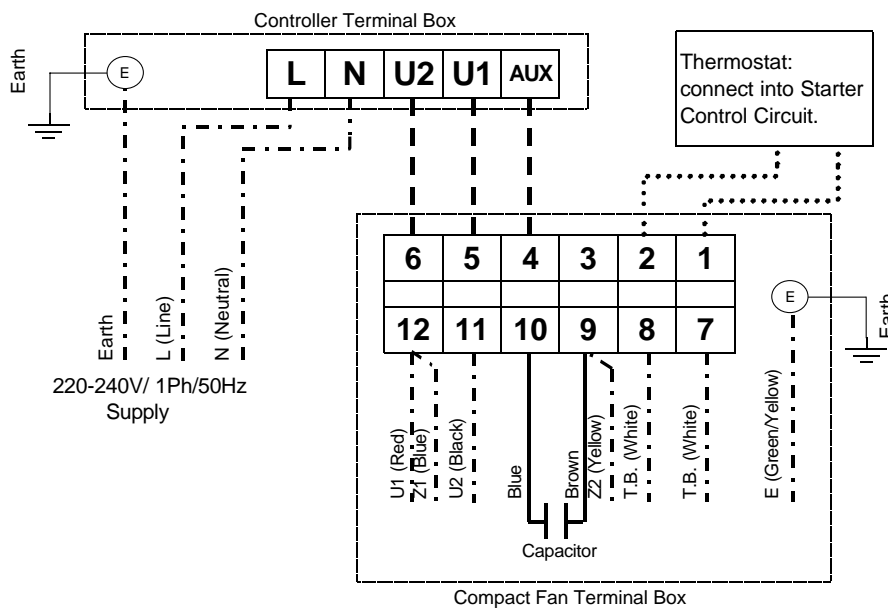

NOTE: THE ABOVE WIRING DIAGRAM APPLIES TO INSTALLATIONS WHERE **ELTA FANS** CONTROLLERS ARE USED. FOR USE WITH ALTERNATIVE CONTROLLERS REFER TO MANUFACTURER'S WIRING DIAGRAM. FAILURE TO CONNECT BUILT-IN MOTOR THERMOSTAT PROTECTION MAY INVALIDATE WARRANTY. TO CHANGE MOTOR / FAN ROTATION INTERCHANGE Z1 AND Z2.