

Heavy Duty Floor Grilles

HDFG

Waterloo

Introduction

The Waterloo HDFG heavy duty floor grille has been designed for commercial and industrial applications where heavy foot traffic is experienced. The S type is a 600mm tile replacement and L type is for linear applications; both are available with a recessed border style. This improved design is suitable for use with most types of raised floor pedestal system.

Product description

- HDFG-XS** Extra heavy duty tile replacement with steel subframe
- HDFG-S** Standard tile replacement
- HDFG-L** Linear
- OBSS** Opposed blade damper
- BL** Blanking plate

Features

- HDFG-XS tested to PSA MOB PF2 PS/SPU specification dated March 1992
- Reversible core (0° or 15° discharge)
- Suitable for most pedestal flooring systems
- Facility for on site blanking of linear version
- Recessed border style
- Border alignment facility on linear version

Finish

Mill finish as standard, powder or nylon coating options available on request.

Advantages

- Integrated design features - enabling tile and linear grille combinations for aesthetic continuity
- Improved additional strength design
- Easy "Drop in" installation
- Convenient damper adjustment

Weights

18.0 kg/m² face area

Sizes

- HDFG-S & XS 600 x 600mm
- HDFG-L Length - maximum single section 1000mm
- Width - maximum 600mm
- minimum 100mm

Order Example

HDFG-L/1000x300/MILL/OBSS/BL

Type _____
 Section Length _____
 Section Width _____
 Finish _____
 Damper _____
 Blanking Plate _____

HDFG/L

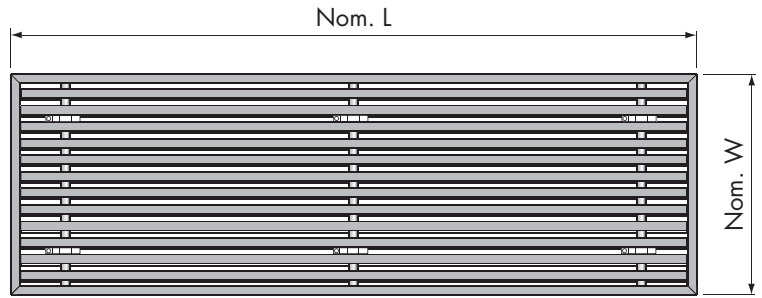

Single unit

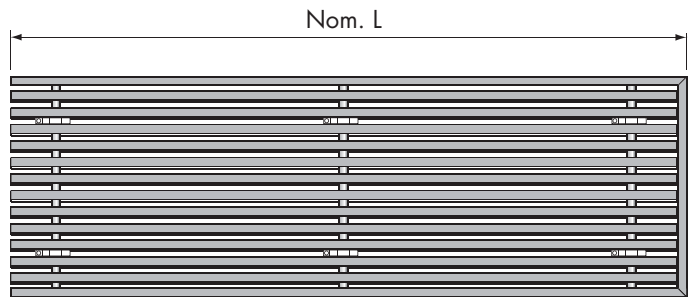

End section

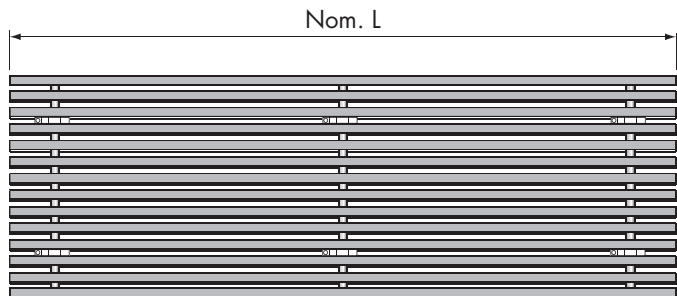

Intermediate section

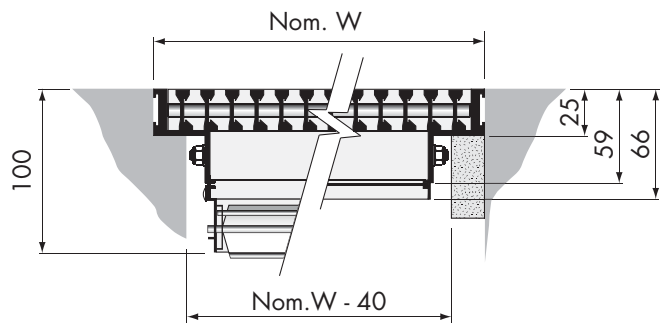

HDFG-L + OBSS // HDFG-L + BL

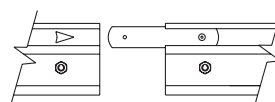

2 alignment strips supplied with each section for site fixing.

Free Area

47%

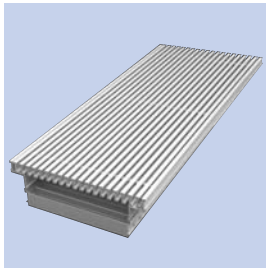

Please refer to page 2 for used symbols, definitions and criteria.

Selection Example

HDFG-L/1200x200

Air Volume 250 l/s/m
Throw 3.6 m
Pressure Drop 7 Pa
Noise Level NR 22

Spectrum Corrections

Frequency (Hz)	125	250	500	1k	2k	4k
Supply	+9	+13	+12	+6	+2	-2
Exhaust	+9	+11	+12	+0	-5	-11

Performance Tables

HDFG-L		Supply Nom.Grille Width (mm)						Extract Nom.Grille Width (mm)						
m ³ /h/m	l/s/m	100	150	200	300	450	600	100	150	200	300	450	600	
180	50	T	1.8											
		P _s	2					3						
		L _p	<20					<20						
270	75	T	2.7	1.5										
		P _s	4	1				6	2					
		L _p	<20	<20				<20	<20					
360	100	T	3.6	2.3	1.3									
		P _s	7	3	1			13	4	2				
		L _p	22	<20	<20			27	<20	<20				
450	125	T	4.4	2.7	1.8									
		P _s	12	4	2			20	6	3				
		L _p	29	<20	<20			34	<20	<20				
540	150	T	5	3.2	2.3	1.3								
		P _s	16	6	3	1		28	9	4	2			
		L _p	32	20	<20	<20		39	23	<20	<20			
630	175	T	5.5	3.6	2.7	1.7								
		P _s	22	7	4	2		37	13	6	3			
		L _p	35	22	<20	<20		43	27	<20	<20			
720	200	T	6	4.2	3	2								
		P _s	29	10	6	3		50	17	9	4			
		L _p	39	26	<20	<20		47	32	21	<20			
900	250	T		4.9	3.6	2.5	1.3							
		P _s		16	7	4	1		28	13	5	2		
		L _p		32	22	<20	<20		38	27	<20	<20		
1080	300	T		5.5	4.3	2.7	1.8	1.2						
		P _s		22	11	4	2	1		37	18	6	3	2
		L _p		36	27	<20	<20	<20		43	32	<20	<20	<20
1440	400	T		7.3	5.7	4	2.7	2						
		P _s		32	22	10	4	2			39	17	6	3
		L _p		45	36	26	<20	<20			45	31	<20	<20
2160	600	T			7	5	3.6	2.7						
		P _s			44	17	7	4			30	13	6	
		L _p			43	32	22	<20			43	27	<20	
2880	800	T				6.2	4.5	3.4						
		P _s				30	13	7				22	10	
		L _p				39	30	20				37	25	
3600	1000	T				7.2	5.5	4.3						
		P _s				47	21	11				36	18	
		L _p				44	37	28				45	35	

HDFG-S		600x600 Tile Replacement		
m ³ /h	l/s		Supply	Return
1080	300	T	2.3	
		P _s	3	5
		L _p	<20	<20
1440	400	T	3	
		P _s	6	8
		L _p	<20	<20
1800	500	T	3.6	
		P _s	8	12
		L _p	22	27
2160	600	T	4.3	
		P _s	11	18
		L _p	28	35

Load Deflection Characteristics

HDFG-XS Floor Grille 600 x 600

Tested to PSA MOB PF2 PS/SPU specification dated March 1992

HDFG-S Floor Grille 600 x 600

Load applied on grille centre line distributed over 25mm x 25mm point between subframe supports.

Maximum recommended point load 400kg.

HDFG-L Floor Grille 300mm Wide

Load applied on grille centre line distributed over 25mm x 25mm point between blade supports.

Maximum recommended point load 360kg.

HDFG-S Floor Grille 600mm Wide

Load applied on grille centre line distributed over 25mm x 25mm point between blade supports.

Maximum recommended point load 180kg.

HDFG-S - 600x600

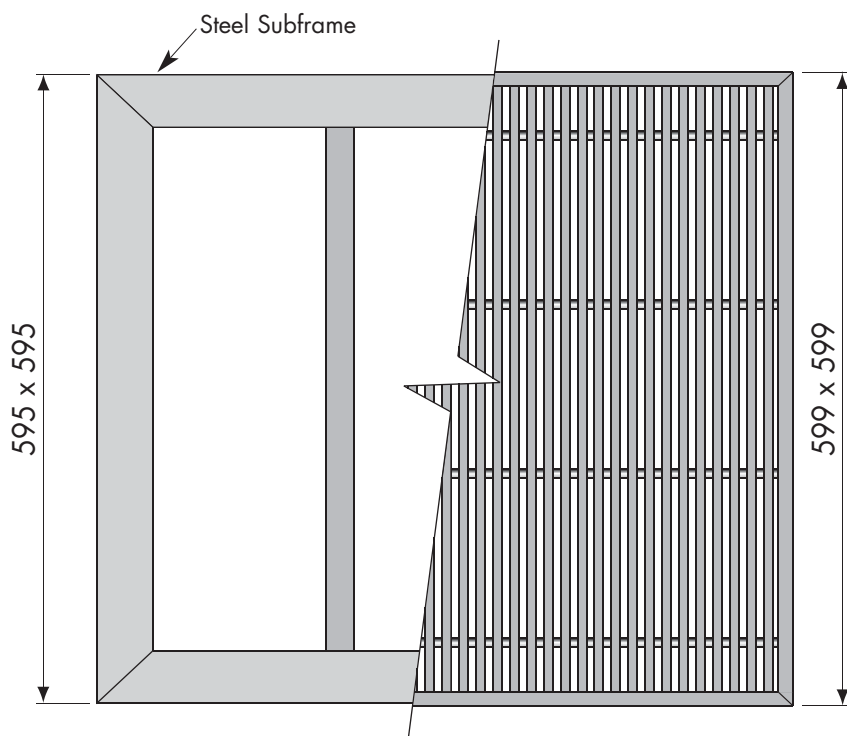
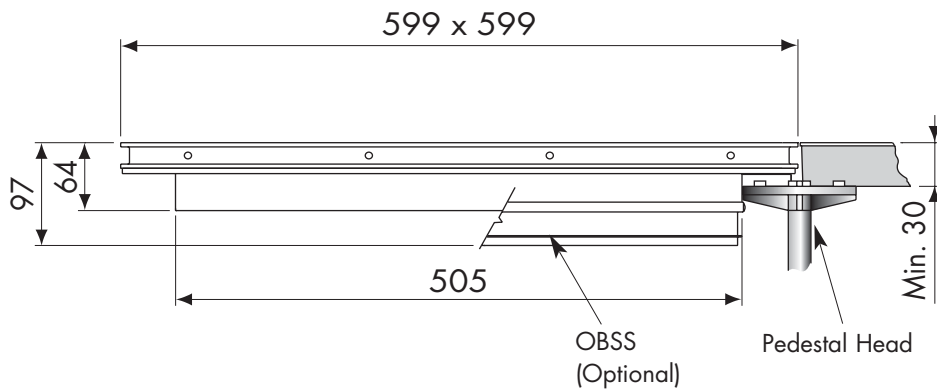

Order Example

HDFG-S/600x600/MILL/OBSS

Type _____
 Nominal Width _____
 Nominal Height _____
 Finish _____
 Option _____

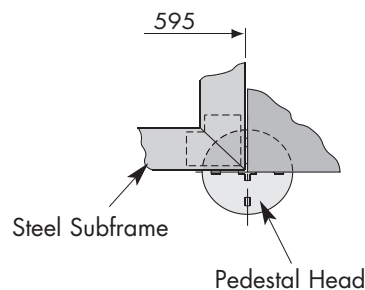

Where possible, full details of pedestal system & finished tile thickness should be provided with order

HDFG-L - Linear Corner Sections

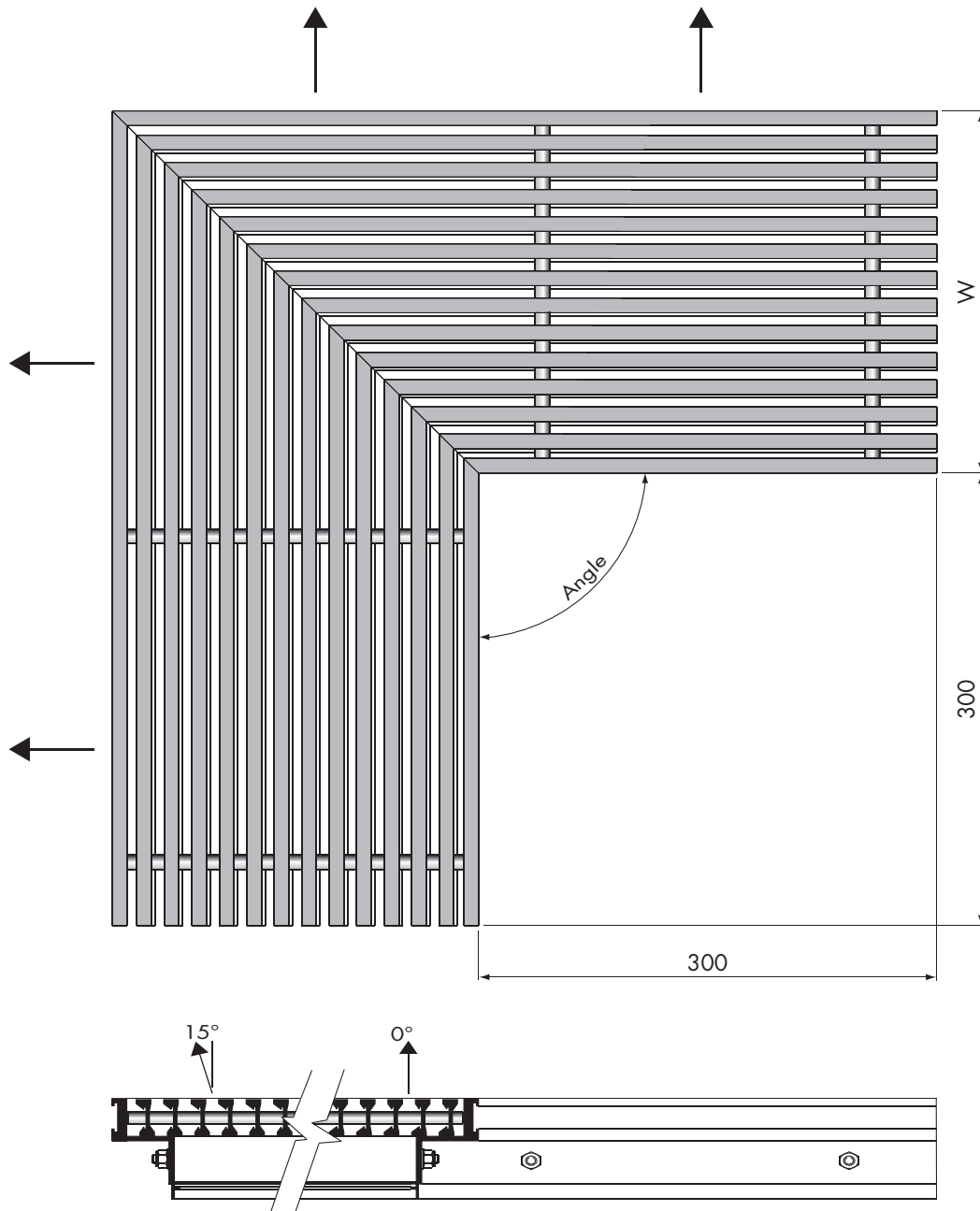

Note:

Orders for corner sections will be made to the configuration shown with a 90° angle. Requirements for angles other than 90° should be identified with a customer drawing or site template.

Orders for installations which include corner sections should clearly identify any preference for core discharge angle relative to the layout (0° or 15°). Unless specified otherwise, corners will be manufactured for 0° deflection.

Order Example

HDFG-L/300/90°/300/100/MILL

Type _____
 Length 1 _____
 Corner Angle _____
 Length 2 _____
 Section Width (W) _____
 Finish _____