

# Airline Linear Grilles

## ALN ALM ALF ALG ALJ

# Waterloo

### Introduction

Waterloo airline linear grilles have been designed to satisfy air diffusion and engineering requirements as well as architectural specifications. Airline grilles may be used in modular or continuous situations for ceiling, sidewall, cill or bulkhead applications. The range is available with a wide variety of special options and fabrications to suit most project requirements. Grilles may be supplied with or without frames and borders - cores are represented with a suffix "(C)".

### Product Description

- ALN** 0° 6mm thick blade, 12.5mm pitch
- ALM** 15° 6mm thick blade, 12.5mm pitch
- ALF** 45° 5mm thick blade, 12.5mm pitch
- ALG** 0° 3mm thick blade, 12.5mm pitch
- ALJ** 15° 3mm thick blade, 12.5mm pitch
- ALG10** 0° 3mm thick blade, 10mm pitch
- ALJ10** 15° 3mm thick blade, 10mm pitch
- ALG2** As above with a rear set of adjustable blades
- ALJ2** As above with a rear set of adjustable blades
- ALN2** As above with a rear set of adjustable blades
- ALM2** As above with a rear set of adjustable blades
- 2ALF** 2 way cores are available on angled blade designs (Suffix M, F or J)
- OBSS** Allen Key operated opposed blade damper
- ED** Equalising deflector
- DT-2M** Adjustable duct turn (Installed in duct)
- ALF-RB** Reverse Border (Any blade can be specified)

### Finishes

- PPM9006 (RAL 9006 Matt Silver)
- PPM9010 (RAL 9010 20% Gloss White)
- PPG9010 (RAL 9010 Gloss White)
- Other colours or anodised finish available on request

### Weights

- ALG 14 kg/m<sup>2</sup> face area
- Others 10 kg/m<sup>2</sup> face area
- OBSS/ED 9.5 kg/m<sup>2</sup> face area
- DT2M(G) 9.0 kg/m<sup>2</sup> face area

### Sizes

- Minimum size - 150 x 50mm
- Maximum single section of cores - 1500 x 800mm
- Refer to head office for borders upto 4 meters in one piece
- Continuous grilles are supplied in sections for butt jointing on site.

### Order Example

**ALG/1000x150/PPM9010/R25/SF/OBSS**

Type \_\_\_\_\_  
 Nominal Width \_\_\_\_\_  
 Nominal Height \_\_\_\_\_  
 Finish \_\_\_\_\_  
 Border \_\_\_\_\_  
 Fixing \_\_\_\_\_  
 Option \_\_\_\_\_

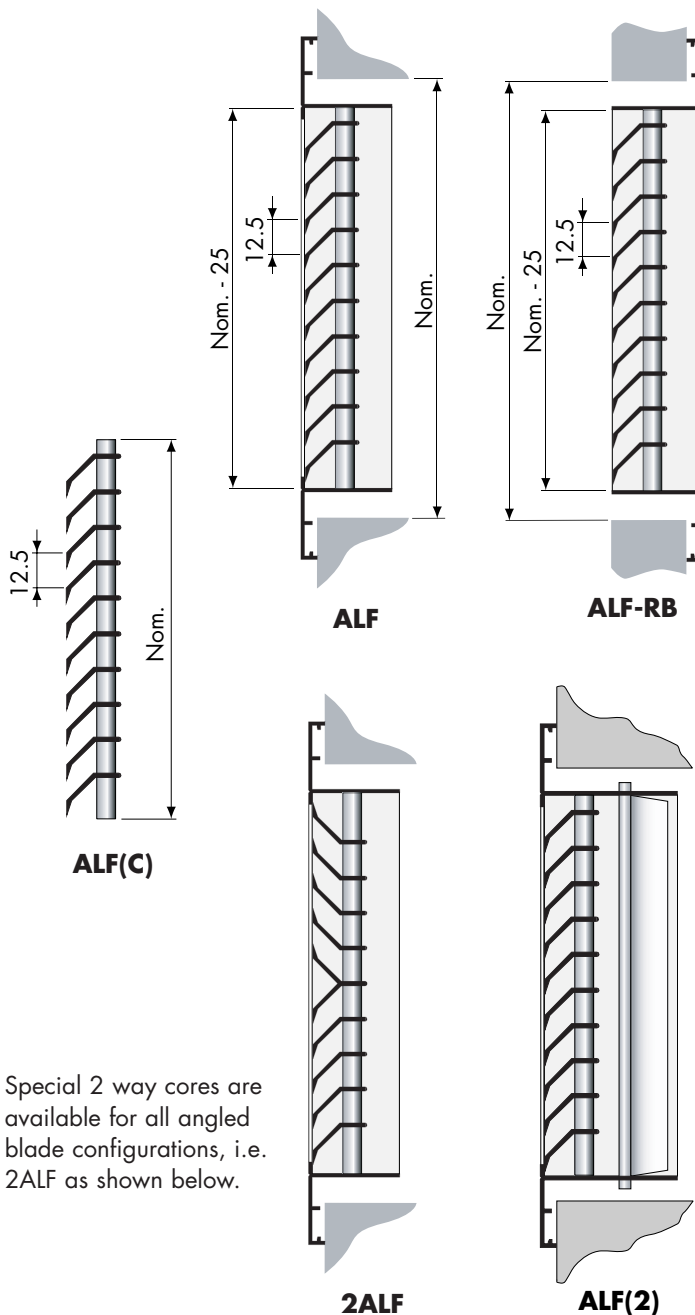

Special 2 way cores are available for all angled blade configurations, i.e. 2ALF as shown below.

### Fixing Options

- |       |       |     |      |      |
|-------|-------|-----|------|------|
| SF    | CF    | VS  | AFVS | PFVS |
| ARCF  | RCCF  | CRB | RCHS | AFHS |
| BSSBD | BSSBP |     |      |      |

The following fixings are not compatible with the ALF blade

- CRB RCHS AFHS BSSBD

BSSBP - Not suitable for grilles with a rear blade or ALF blade.

Please refer to pages 40-43 for full details of:

- Fixing Options
- Control Options.
- Sub Frames
- Sizing Implications
- Border Options

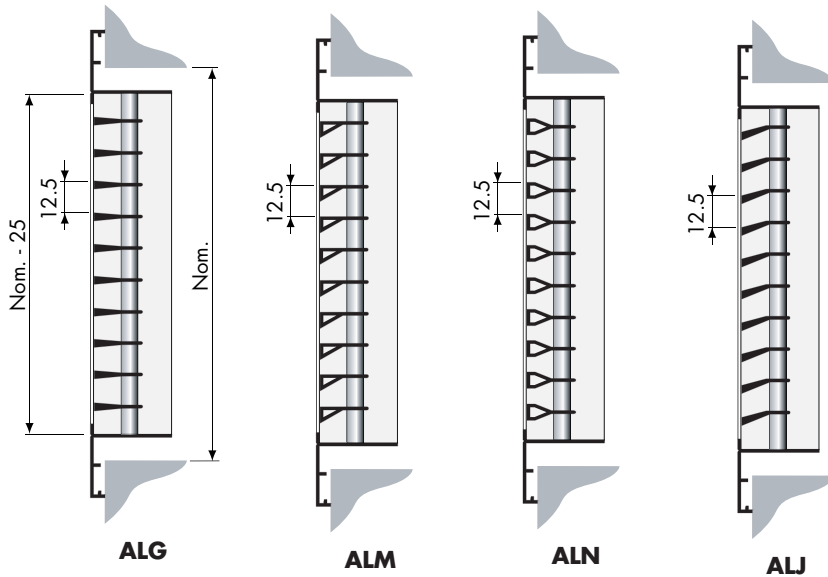

Free Area					
Pitch	Type				
	ALG	ALJ	ALF	ALM	ALN
10mm	68%	68%			
12.5mm	74%	74%	44%	49%	49%

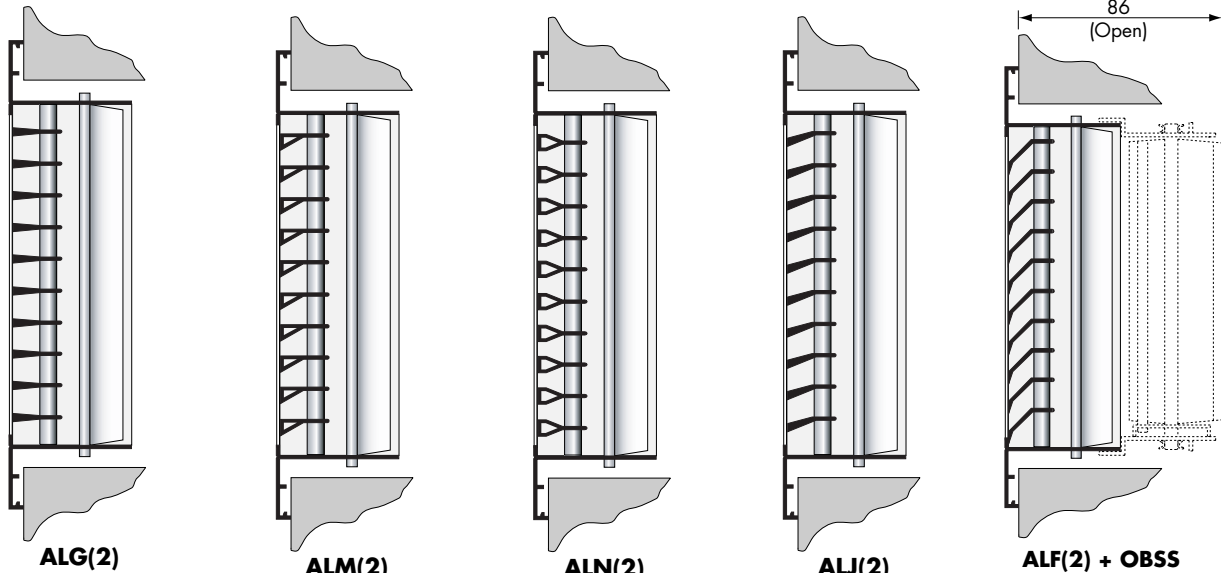

**ALG(2)**  
ALG Blade  
Blade Angle 0°  
Blade Thickness 3mm

**ALM(2)**  
ALM Blade  
Blade Angle 15°  
Blade Thickness 6mm

**ALN(2)**  
ALN Blade  
Blade Angle 0°  
Blade Thickness 6mm

**ALJ(2)**  
ALJ Blade  
Blade Angle 15°  
Blade Thickness 3mm

**ALF(2) + OBSS**  
ALF Blade  
Blade Angle 45°  
Blade Thickness 4mm

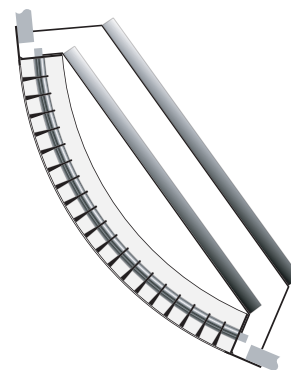
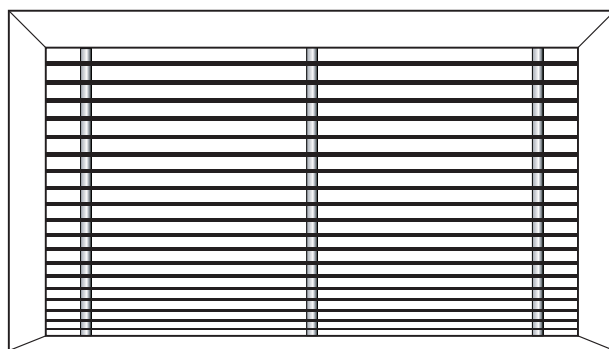

**Curved ALG Grille**

### Example of Waterloo's Bespoke Manufacturing Capability:

We at Waterloo pride ourselves on our ability to meet tough design requirements for bespoke products. If you don't see what you are looking for in the brochure, please call our head office on the phone number at the bottom of the page.

### Correction Factors

Terminal Velocity Correction Factors				
$V_t$ (m/s)	0.6	0.5	0.4	0.3
Throw Multiplier	x0.8	x1.0	x1.3	x1.66

Grille Length Correction Factors						
Length (m)	0.25	0.5	1.25	2	2.5	3
$L_p$	-6	-3	0	+2	+3	+5
T	x 0.9	x 0.9	x 1.0	x 1.0	x 1.1	x 1.1

Non-isothermal Jet Correction Factors			
Differential	10°C Cooling	0°C	10°C Warming
Sidewall Throw	x 0.9	x 1.0	x 1.1
Cill Throw	x 0.9	x 1.0	x 1.1

### Notes:

For grilles with OBSS opposed blade damper (open), multiply the pressure loss by 1.5 and add 3dB to the NC level.

Where AL2 grilles are used multiply  $P_s$  x 3.0 and add 6dB to NC level.

Grille selections for sidewall and cill applications should be based on a minimum discharge velocity of 2m/s.

For sidewall grilles that are to be mounted more than 0.2m from the ceiling, it is preferable to use a 15° blade format.

For sidewall grilles mounted 0.5m or more below ceiling level the throw is reduced by 1/3.

### Performance Nomogram (Supply)

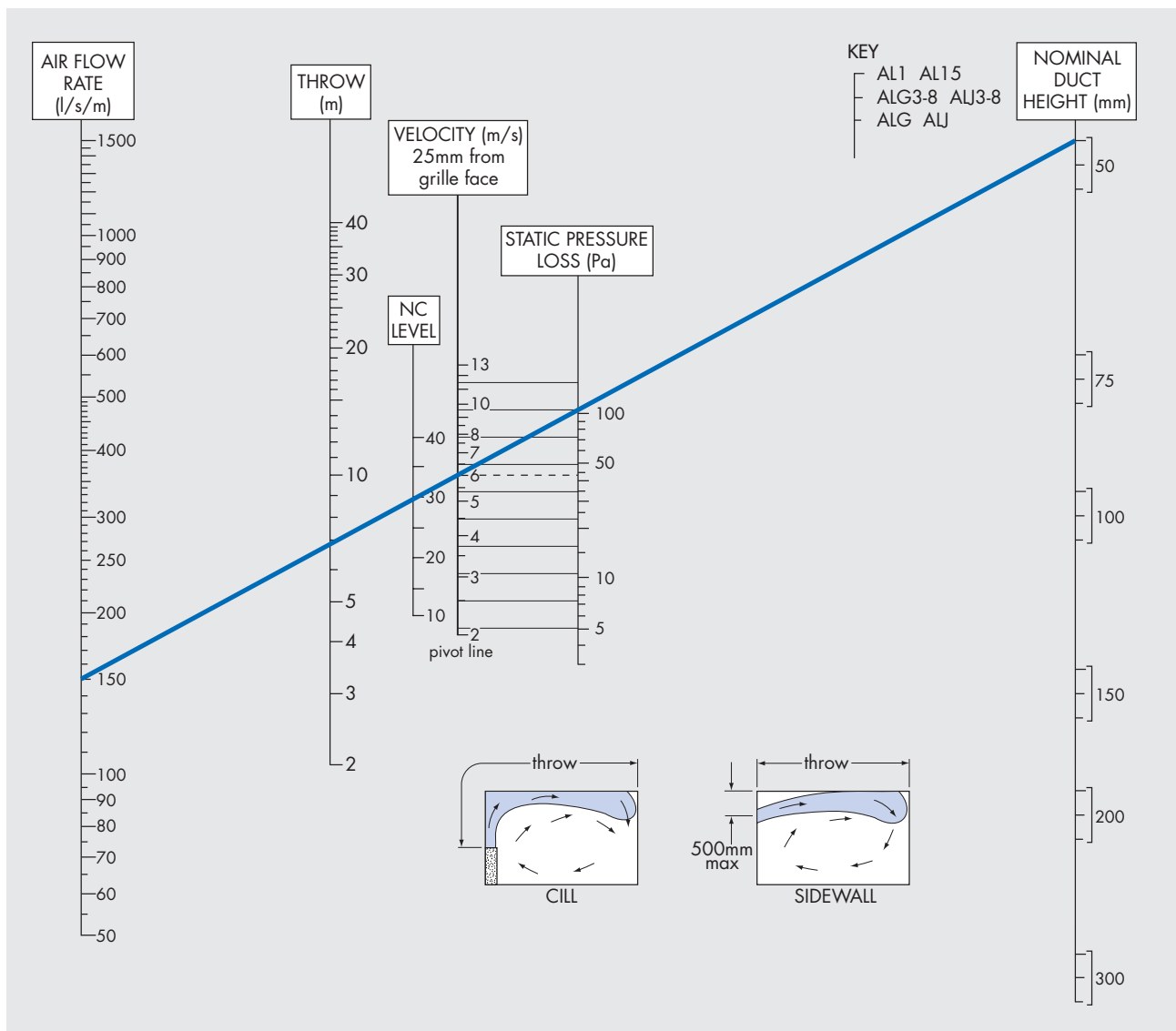

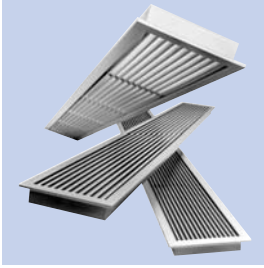

### Selection Criteria

Performance data is derived from tests carried out in accordance with BS 4773 Pt I & Pt II and is based on isothermal conditions for a 1.25m long grille mounted 0.2m below a ceiling surface.

Throw is the horizontal distance to where the envelope velocity equals 0.5m/s.

### Selection Example 1250mm Long by 50mm Wide Grille Supplying 100 l/s/m

<b>ALF</b> P <sub>S</sub> = 65Pa	NC35	<b>ALF/OBSS</b> P <sub>S</sub> = 98Pa	NC43
<b>ALN</b> P <sub>S</sub> = 22Pa	NC24	<b>ALN/OBSS</b> P <sub>S</sub> = 33Pa	NC32
<b>ALG 10</b> P <sub>S</sub> = 18Pa	NC27	<b>ALG 10/OBSS</b> P <sub>S</sub> = 27Pa	NC35
<b>ALG</b> P <sub>S</sub> = 16Pa	NC24	<b>ALG/OBSS</b> P <sub>S</sub> = 24Pa	NC32

Please refer to page 2 for used symbols, definitions and criteria.

### Performance Nomogram (Exhaust)

