

Linear Diffusers Plenum Chambers

Introduction

Correct selection and sizing of distribution plenum chambers and neck reducers is critical because terminal air resistance is very low relative to the distribution ductwork resistance. It is therefore recommended that whenever possible terminals are served by low velocity stub ducts from branch ducting systems fitted with correct balancing controls.

Where it is necessary to specify and use plenums a generous allowance for commissioned noise generation should be made. A similar effect results from use of neck reducers with circular duct connections because the reduced duct area will cause generally higher velocities and hence increased risk of noise generation.

Product Description

- PBHL** High-line Plenum chamber
- PBLL** Low-line Plenum chamber
- SE** Side Entry spigot
- TE** Top Entry spigot
- EE** End Entry spigot
- CC** Circular connection
- RC** Rectangular connection
- LINED** 6mm Type "O" fire rated acoustic lining
- BAFFLE** Perforated plate for more even air flow to diffuser

Installation

The plenum boxes and neck reducers are supported by 4 drop rods through a locating hole positioned near each corner.

When ordering plenum chambers please specify length width & height, spigot size and position (top or side entry) and control options. Please note that the plenum height should in general be 100mm greater than the spigot diameter (side entry applications).

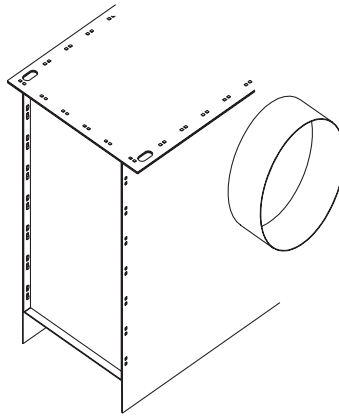

High-line plenum chamber

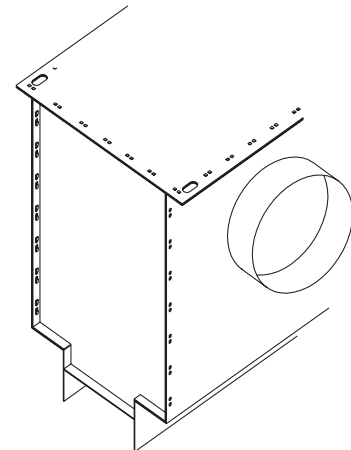

Low-line plenum chamber

Control Options

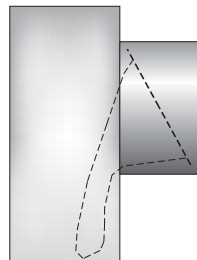

FDC

Cord operated flap damper for mounting within circular spigots to plenum chambers.

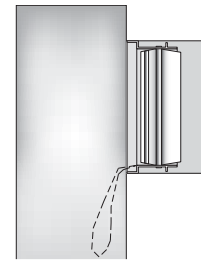

OBCO

Cord operated opposed blade damper for installation within square or rectangular plenum spigots.

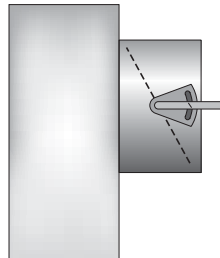

FDQ

Flap damper with external quadrant control for mounting within circular spigots to plenum chambers.

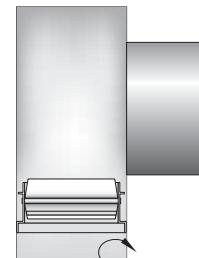

OBSS / ED

Standard opposed blade damper for diffuser or duct mounting

Order Example

PBHL/CSF/1200 x 250 x 250/SE/150/2CC/OBSS/Lined

Type _____

Diffuser Type _____

Plenum Chamber Length _____

Plenum Chamber Width _____

Plenum Chamber Height _____

Entry _____

Spigot Size _____

Spigot Connections _____

Option _____

Option _____

Recommended Max Air Volume for NR35 Based on Recommended Spigot Sizes

Diameter	100	125	160	200	250	315	400
l/s	28	42	70	100	165	260	



Selection Example

Using the CS example from page 5, we have a diffuser handling 180 l/s total with a pressure drop of 25 Pa. Projecting from this volume through the diffuser pressure loss, then pivot on the plenum dimensions to suit the diffuser 2 slot width, which gives a minimum plenum height of approx 280mm. Draw a line from the air flow selection point through the required spigot air velocity and read off the

nearest standard spigot size. In this example the spigot diameter exceeds the selected plenum height, so the height now becomes $315 + 100 = 415\text{mm}$. Alternatively, to maintain the original height, select a suitably sized rectangular spigot (300 x 200 in the example) or use multiple circular spigots.

Performance Nomogram

