

Aircell Diffusers

2300 2600

Introduction

The Waterloo Aircell 2000 series presents a contemporary diffuser style combining high performance and robust construction with the significant cost advantage of injection moulded engineering polymers. The diffusers are available in 2 sizes to integrate with standard 300mm or 600mm lay-in or concealed 'T' ceiling systems.

Product Description

- 2300** 300 sq diffuser
- 2600** 600 sq diffuser
- O** Black polymer opposed blade damper
- P** Black polymer plenum box
- F** Fixing kit
- B** Blanking kit

Features

- Contemporary style designed for visual integration with luminaires and other ceiling elements
- Ease of installation with concealed, single point fixing into P series plenum or rigid ducting
- Full range of integrated accessories available including directional or core blanking kits, universal plenums and opposed blade dampers

Finishes

Diffusers are self-coloured white
Damper and plenum are self-coloured black

Weights

- 2300 0.6 kg
- 2600 3.2 kg

Authority

Patents: 2221530, 2223840, 8818337 others pending
Registered Designs: 1052716, 106216
Fire Rating: BS476 Pt 7 Class 0. BS476 Pt 5, P Rating. BS 2782 Method 508A, Zero Rate of Burn.

Performance tested to BS4773 1991, ISO 5219.

Maximum supply air temperature must not exceed 50°C.

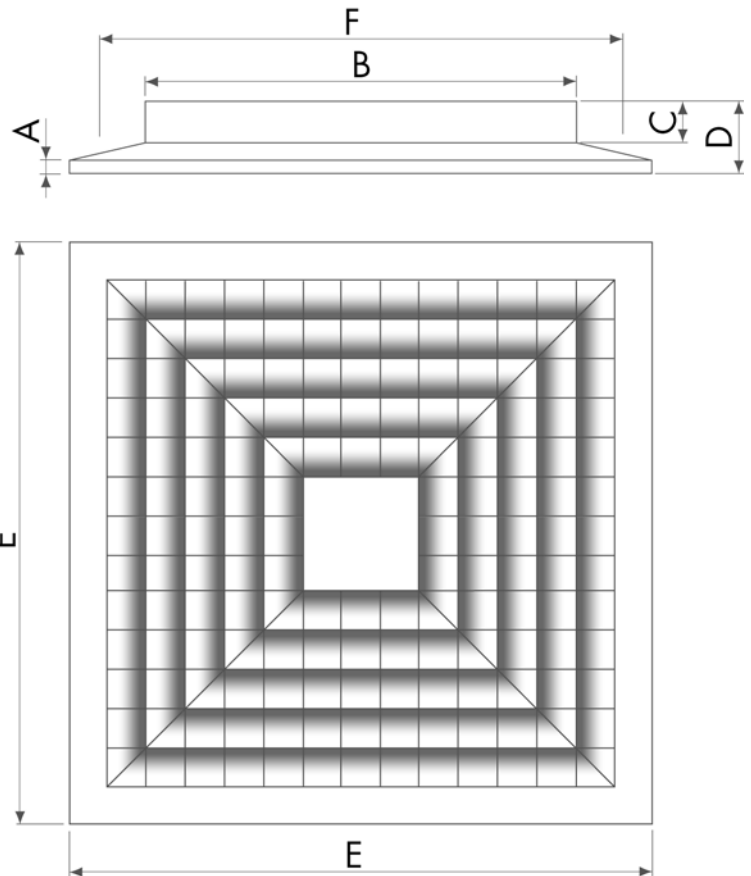

Order Example

Aircell 2300/O300/P300/F300/B300

- Type
- Damper
- Plenum
- Fixing kit
- Blanking kit

Aircell 2000	A	B	C	D	E	F
2300	3	229	41	53	296	269
2600	6	459	31	56	596	546

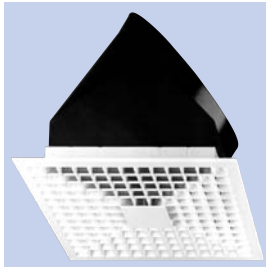

Selection Criteria

Ceiling Height 2.7 m
 Temperature Differential -10K
 Average room velocity v_r 0.25 m/s
 NR level = peak level on noise rating curves based on Sound Power Level less 8dB room absorption

Selection Example Aircell 2300-4

Air Flow Rate 75 l/s
 Throw 1.1 m
 Static Pressure Loss 17 Pa
 Noise level NR22

Note: Sizes are overall

All performance data includes the plenum box

Performance Table

2000		Supply					Supply				Exhaust	
Air Volume		2300					2600				2300	2600
l/s	m ³ /h		4 way	3 way	2 way	1 way	4 way	3 way	2 way	1 way		
25	90	T (m)	0.6	0.7	0.8	1.7						
		Ps	2	5	8	28					4	
		Lw	-	-	-	30					-	
50	180	T (m)	0.8	1.4	1.7					0.9		
		Ps	8	17	28					10	15	
		Lw	-	20	30					20	19	
75	270	T (m)	1.1	1.7	2.3					1.8		
		Ps	17	28	60					22	30	
		Lw	22	30	41					31	29	
100	360	T (m)	1.7	2.2					0.9	2.5		
		Ps	28	50					10	40	50	
		Lw	30	38					20	38	35	
125	450	T (m)	2.0	2.5			0.3	0.7	1.4			
		Ps	44	66			4	8	15		75	
		Lw	36	43			-	-	26		40	
150	540	T (m)	2.3				0.5	0.9	1.8			
		Ps	60				6	10	22		100	6
		Lw	41				-	20	31		45	-
200	720	T (m)					0.9	1.6	2.5			
		Ps					10	18	40			12
		Lw					20	28	38			-
250	900	T (m)					1.4	2.1				
		Ps					15	28				20
		Lw					26	33				20
300	1080	T (m)					1.8	2.5				
		Ps					22	40				29
		Lw					31	38				27
350	1260	T (m)					2.2					
		Ps					30					41
		Lw					35					32
400	1440	T (m)					2.5					
		Ps					40					54
		Lw					38					37

Blanking arrangements

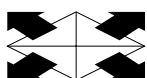

4 way

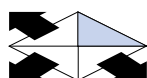

3 way

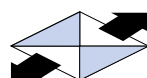

2 way



2 way

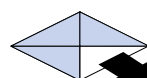

1 way

Copyright:
Waterloo Air Products
2005

Performance

The unique integrated design of the plenum, damper and diffuser assembly has been specifically developed to promote smooth flow lines, ensuring an exceptional aerodynamic and acoustic performance.

Aircell products can be used in any air distribution systems where temperatures do not exceed 50° C.

The components have been tested to BS4773 Parts 1 & 2 to provide comprehensive, easy to use selection data for all installation options.

Opposed Blade Damper Type 'O'

The 'O' series opposed blade damper is designed to integrate with the plenum and diffuser range to provide a simple means of flow regulation from the diffuser face.

The unit is designed to snap fit into the universal plenum, or alternatively can be easily screw or rivet fixed into steel ducting using the inbuilt mounting lugs.

Manufactured in black engineering grade polymer, the damper is inherently smooth and positive in operation.

Weights

O300	0.5 kg
O450	1.0 kg
O600	2.2 kg

Plenum Type 'P'

The 'P' series plenum is aerodynamically profiled to provide ideal flow conditions with either top or side entry duct arrangements.

Manufactured in black engineering grade polymer, the design incorporates features such as internal guide vanes to reduce air turbulence, and snap-in locks to retain the opposed blade damper and diffuser mounting bar.

The plenum can be fixed to the ceiling grid or suspended by drop rods from the slab. Either fixing method is carried out using patented mounting brackets which simply slide into the plenum retaining slots.

Weights

P300	0.7 kg
P450	1.0 kg
P600	1.7 kg

Neck Reducer R600

The R600 snap-fit neck reducer is available as an option to convert the P600 plenum spigot from 397ø to 312ø.

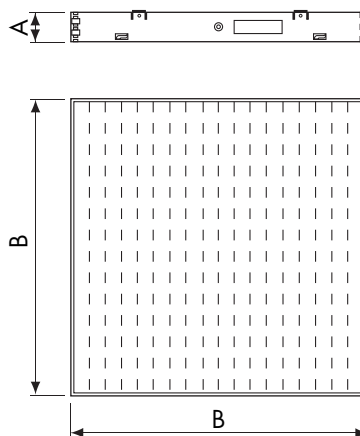

Type 'O' damper

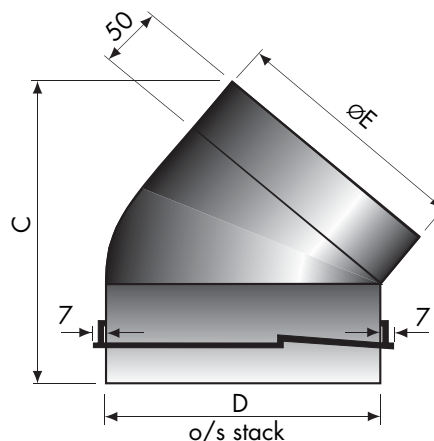

Type 'P' plenum

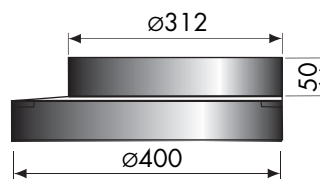

R600 neck reducer

Model	A	B	C	D	E
O300	41	215	-	-	-
O450	41	290	-	-	-
O600	41	440	-	-	-
P300	-	-	245	224	197
P450	-	-	277	299	247
P600	-	-	366	449	397

Installation

Particular attention has been paid to the installation method to minimise site fixing time. The plenum is easily installed using the slide-in brackets as support legs from above the ceiling 'T', or with drop rods from the slab. The damper and diffuser support bar can then be clipped in place, with the diffuser finally being secured by the single centre fixing screw.

Specification

Ceiling diffusers shall be Aircell 2000 series manufactured from injection moulded engineering polymer, in self-coloured white as standard. Overall diffuser size shall be nominally 300 or 600mm to suit standard ceiling grids.

A captive centre line polymer fixing bolt and metal fixing bracket kit shall be provided.

Directional blanking is obtained with snap-in plates to provide 1, 2 or 3 way air patterns or reduced area blanking.

Opposed blade dampers (type 'O') is manufactured from injection moulded engineering polymer in self-coloured black as standard, operable through the diffuser face.

Plenum box (type 'P') is manufactured from injection moulded engineering polymer of a universal design and in self-coloured black, incorporating guide vanes and bracket location slots.

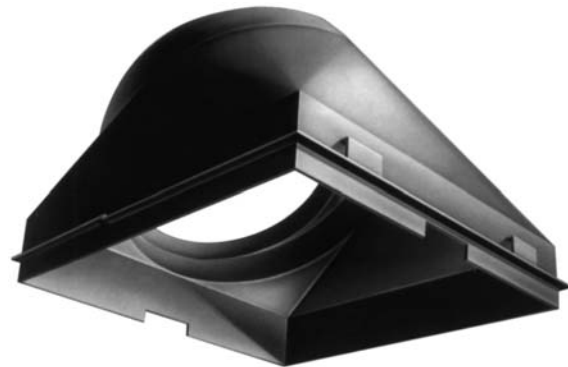

Note:
Specially designed clips mean that you can use a type 'O' damper with a diffuser without a universal Plenum.

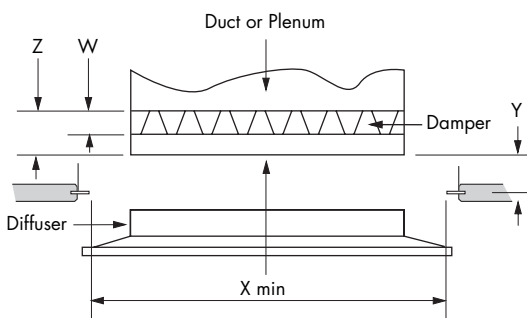

- W = Damper depth
- X = Ceiling opening (+5 -0)
- Y = Face of T bar to underside of Duct or Plenum (+0 -10)
- Z = Underside of duct to underside of damper

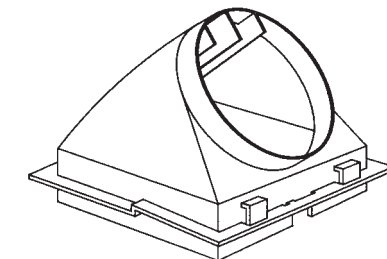

Universal plenum type P

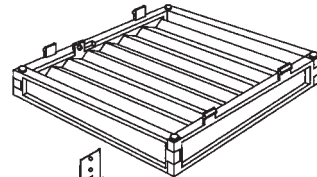

Face operated opposed blade damper type O

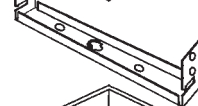

Diffuser fixing bracket type F - for fixing to plenum or duct

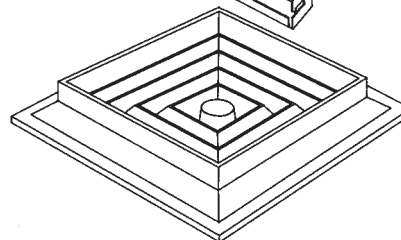

Aircell diffuser

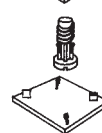

Captive fixing bolt

Removable core

Model	W	X	Y	Z
2300	45	269	41	88
2600	45	546	41	88